

SECTION A-A

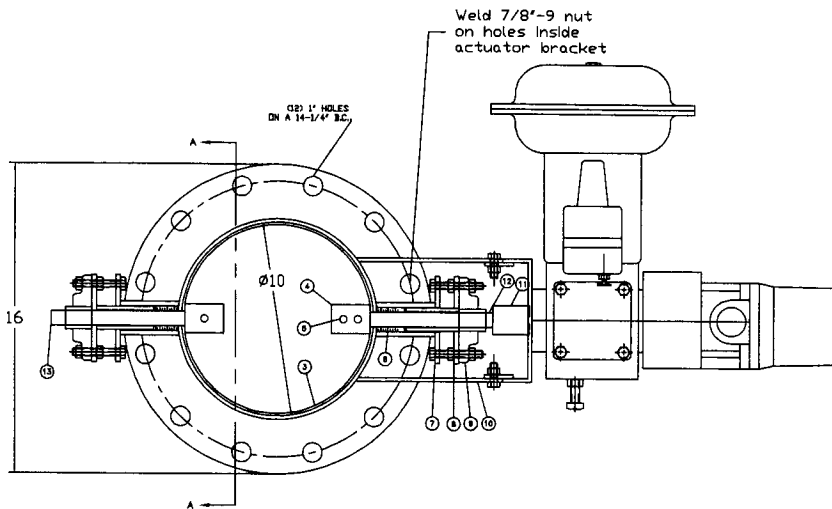

STUB SHAFT	13	1" DIAM 304SS	1
DRIVE SHAFT	12	1" DIAM 304SS	1
ACT ADAPTOR	11	1-1/2" DIAM 304SS	1
ACT BRACKET	10	1/4" A36	1
DOUGE BEARING	9	SC 2-BOLT	2
PK PUSHER	8	1/4" A36	2
PK GLAND	7	1/4" A36	2
PACKING	6	1/4" CARGRAF	12
BLADE PIN	5	1/4" DIAM. 304SS	3
BLADE HUB	4	2" DIAM. 1018CR	2
BLADE	3	1/4" A36	1
BODY	2	1/4" A36	1
FLANGE	1	1/4" A36	2
ITEM NAME	ITEM	DESCRIPTION	QTY
BMAI			

CUSTOMER:
CUSTOMER P.O. #
QTY:
PAINT:
AHS JOB NO#:

002
HI-TEMP ALUMINUM
2378

PLEASE PRINT IN INK ON WHITE PAPER BY HANDWRITING ONLY LABEL PARTS
SPECIALTY VALVE CO. INC. 1000 W. 10TH ST. ST. LOUIS, MO. 63103

REV. DESCRIPTION	DATE	REV.
	CHECKED BY:	DATE
	APPROVED BY:	DATE
	TITLE:	REV.
BY DATE	DRAWING NO.	
REV.	2542-001	

P.O. Box 8
Morton, Mo. 65704
(616) 984-2146